



SHUTTER

CATALOGUE





With our experienced and competent engineering team, we are able to design and manufacture reliable and functional products for many sectors, especially the defense industry. We provide to with our agile and effective decision-making mechanism, we have the ability to quickly design and manufacture products tailored specifically to your needs.

In cameras or binoculars with different features such as thermal, infrared, etc., in image processing machines with sensitive lenses, in many sectors and products used for special purposes such as defense industry and photography, **calibrating** and **protecting** cameras requires reliably designed and precisely operating components.



SHUTTER

The Shutter is a system that ensures that the camera is protected and calibrated in a purposeful way provide to the flag it contains in its structure.

The antireflective coating on the flag ensures complete accuracy for protection and calibration with a light emissivity of over 90%

Its low weight compared to its counterparts, fast response time, low power consumption during standby/running, and compact design make it easy to integrate into the system it will work with.

Enables storage and operation in different climatic conditions

The shutter provides a wide operating range in the systems where it is used with four different flag configurations. Versions with different flag sizes can also be produced according to product requirements.

Features:

- 2.4-4.5 V Supply voltage
- - Operation at temperatures between -40°C and 65°C
- - Storage between 55°C and 65°C
- 2000g 0.5ms and 50g shock resistance
- 8 gram weight
- Power consumption max 10 mW during standby, max 1080 mw during operation
- Flag movement range greater than 45°
- Special Coated Antireflective flag (over 90% emissivity in 7-14 μm infrared light)

Advantages:

- Smooth operation and storage in high and low temperature environments
- Resistance to weapon shocks of different ranges and caliber
- Wide working angle
- Low power consumption
- Compact design
- High light absorption





APPLICATION AREAS



Thermal Imaging
Infrared Imaging

Military applications
Remote Imaging systems



Photography
Hyperspectral imaging
Image processing
Telescopes



Shutter

Dimensional Properties

Dimension for 1. configuration

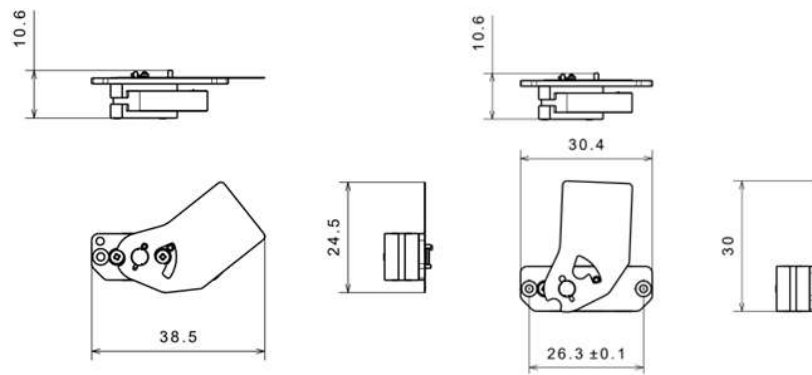

Dimensions for 2. configuration

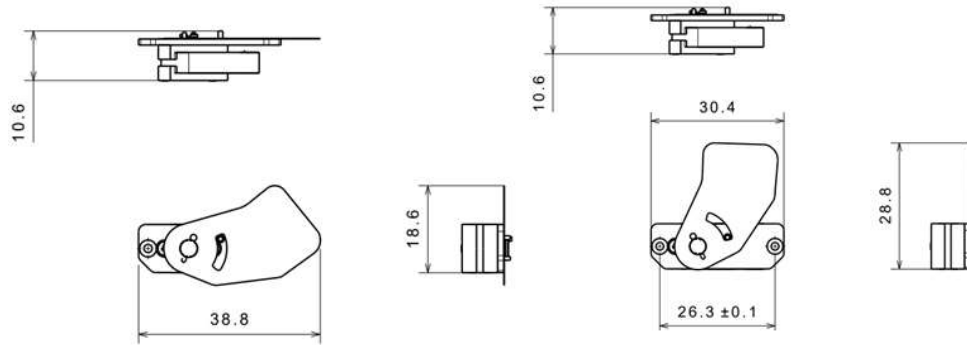

Dimensions for 3. configuration

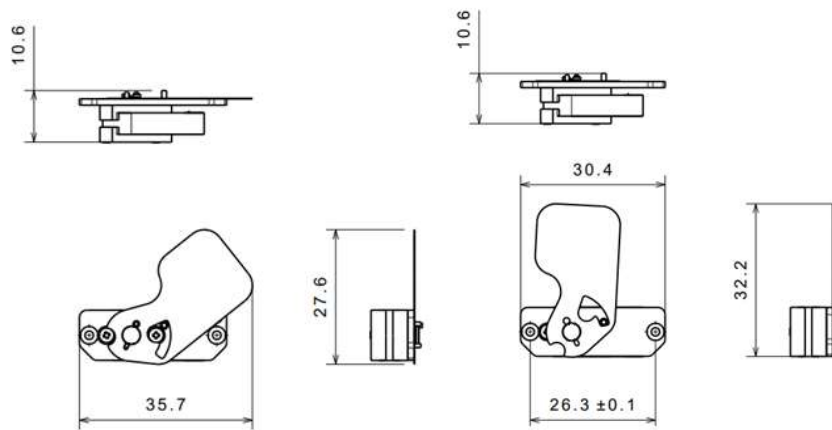

Dimensions for 4. configuration

